

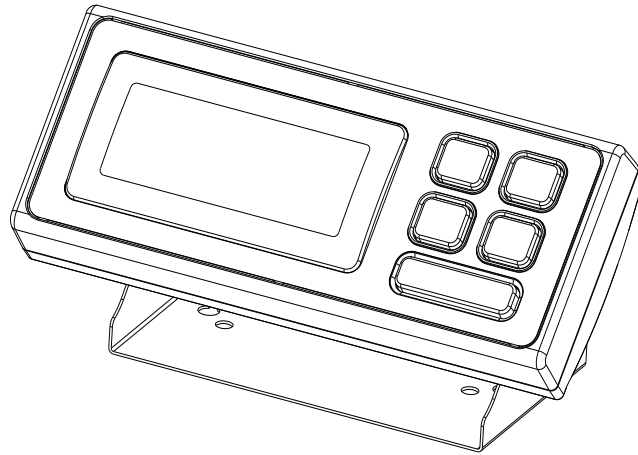

LW MEASUREMENTS, LLC

Professional Weighing Equipment



REMO/REMO-R

Operation Manual

Table of Contents

<u>Section</u>	<u>Page</u>
Declaration of Conformity	3
Customer Service	4
Introduction	4
Safety	5
Weight Scale	6
Features	7
Interface Data	7-8
Getting Started	9
Remo Indicator Mounting Drawing	10
Assembly & Installation	11
Functions	12-13
Calibration	13-14
Maintenance & Service	14
Transportation & Storage	14
Warranty	15

Declaration of Conformity

Declaration of conformity for apparatus with CE mark
We hereby declare that the product to which this declaration refers conforms to the following standards.

Electronic scale: Remo-R

Mark applied	EU Directive	Standards
	2004/108/EC	EN 61326-1: 2006

Signature:



Boon Lim, R & D Manager
Date: 03.07.16

LW Measurements LLC, 620 Carlson Court, Rohnert Park, CA 94928

Customer Service

USA

LW Measurements LLC, Carlson Court,
Rohnert Park, CA 94928
USA
Tel: (707) 542-2185
Fax: (707) 542-3285

<http://lwmeasurements.com>

EUROPE

LW Measurements Europe Ltd
Chalk well Park House 700 London Road
Westcliff-on-Sea Essex SS0 9HQ
United Kingdom

Tel: 01702-476700
Fax: 01702-477380

<http://lwmeasurements.com>

Introduction

What you should know about this Operation Manual:

Tree® Professional Weighing Equipment products are simple to operate. Nevertheless, you should read through these operating instructions in their entirety, so that you can make optimum use of the full potential of the weighing scale in your daily work activities.

These operating instructions contain guidance in the form of pictograms and keyboard diagrams, which should help in finding the required information:

For the labeling of potential hazards, please refer to the Safety proportion of this operation manual.

Safety

Representations & Symbols

Note: Important instructions, which involve safety, are highlighted with the appropriate mark:



Safety recommendations

When using the weighing equipment in surroundings with increased safety requirements, the corresponding regulations must be observed.

The weighing scale may only be used with the power adapter supplied. Before connecting the power adapter to the scale, the user must ensure that the operating voltage stated on the power adapter is compliant with the mains voltage. If not, please contact Customer Service at the address above.

If the power adapter or its cable is damaged, the weighing scale must immediately be disconnected from the electricity supply (pull out the power adapter).

If there should be any reason to believe that it is no longer safe to operate the scale, it should be immediately unplugged from the electricity supply (pull out power adapter) and secured against inadvertent operation.

In carrying out maintenance work, it is essential to follow the recommendations set out in maintenance and servicing.

The weighing scale must not be operated in an area subject to explosion risks.

Care must be taken when weighing liquids to ensure that no liquid is spilled into the inside of the scale or into connections on the rear of the equipment or the power adapter. If liquid is spilled on the scale, it must immediately be unplugged from the main electricity supply (pull out power adapter).

The weighing scale may be operated after it has first been inspected by a service technician.

These operating instructions must be read by each user and should be easily accessible at the workplace at all times.

Weight Scale

PARTS DESCRIPTIONS :

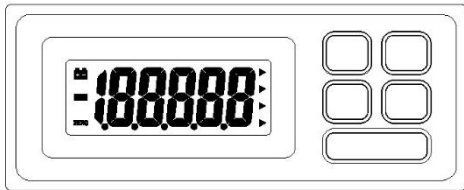



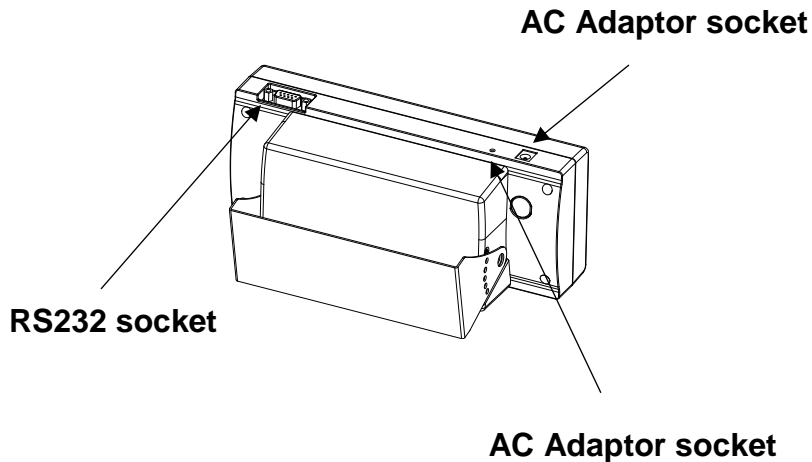

ON/OFF	HOLD
UNIT	ZERO
PRINT	

- **ON/OFF:** Turn the scale power on/off.
- **HOLD:** Press this key to store weight value.
- **UNIT :** Select weighing units : kg or lb.
- **ZERO : (for TARE)**
This key is “Zero” feature if load is below 10% of full capacity or a negative value. Between 10% to full capacity is tare function. It has multiple tare function, but total weight of before and after Tare must be less than its full capacity.
- **PRINT:** Press once and send weight information once.



Features

1. Auto back light (selectable)
2. Auto off (selectable)
3. Hold function
4. Animal weighing
5. Peak hold function
6. Any Cal calibration software
7. RS232 function
8. To work either as an indicator, or a display
9. Three modes: Normal mode / Setting mode /Internal Auto Calibration mode
10. Zero range: $\pm 10\%$ of full capacity
11. Zero Range (0 to 10% of full capacity)
12. Tare Range (10% to full capacity)
13. 4.5Ah Rechargeable battery
14. Display options : 5 digital LCD
15. Power : AC adapter 10V 500mA
16. Operating Temperature : 5~35°C
17. Operating Humidity : 25%~95%RH
18. Error Message indication :
 -  Overload
 -  Unstable when power on
 -  Calibration code is not enough or operation error
 -  Low battery indication

Interface Data :

1 signal interface : (microphone socket)

Red-----→E+ (positive source) / Blue-----→S+ (positive signal)

Black-----→E- (negative source) / Green-----→S- (negative signal)

No sign (yellow) -----→GND

2 recharge battery socket :

AC/DC 10V-----external positive, inner negative

3 RS232 interface : DB9

RS232 TRANSMIT FUNCTION

1. RS232 interface : DB9

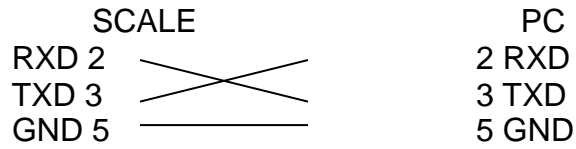

RS232 Transmission Agreement :

- Mode: Simplex Asynchronous Serial
- Baud rate : 9600
- Data Bit : 8
- Parity Bit : NONE
- Stop Bit : 1
- Data Format : ASCII
- Transmission Information Format : 20 Byte, blank=20H

M= Overload Mode

W= Normal Weighing Mode

: = weight information

1	2	3	4	5	6	7	8	9	10	11	12	13	14	15	16	17	18	19	20
W/M	:	±																CR	LF

Weight information

Unit formation

Example: 50kg

1	2	3	4	5	6	7	8	9	10	11	12	13	14	15	16	17	18	19	20
W/M		±							5	0	.	0	k	g				CR	LF

Getting Started

The scale is packaged in an environmentally-friendly carton, which provides optimum protection for the balance during transportation.

We suggest that you keep the original packaging in order to avoid damage if you are shipping or transporting the scale to a different location. It is also the best way to keep it in the best conditions if it will not be used for an extended period of time.

In order to avoid damage, please follow the instructions provided below, when unpacking the scale:

- Unpack the scale carefully.
- When outside temperatures are very low, the scale should be stored for a couple hours and kept in its box in a dry room at normal temperature, so that no condensation settles on the unit when opening the box.
- Check the scale immediately after unpacking for any external visual damage. If there is any damage on scale, contact customer service immediately.
- If the scale is not to be used immediately after purchase, it should be stored in a dry place where fluctuations in temperature are low. (Reference pg.13).
- Read through these operating instruction, before you work with the unit and pay attention to the Safety recommendations (reference Safety pg. 5).

Delivery

Inspect delivery for completeness immediately upon unpacking all components.

Checklist for complete delivery

	Component delivered present yes / no
Weighing unit body	
Power adapter	
Operating manual	

Remo Indicator Mounting Drawing

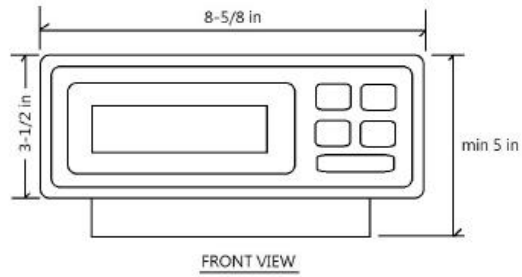
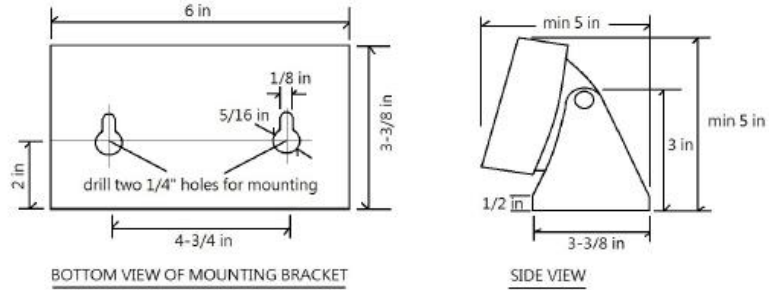

LW MEASUREMENTS, LLC

Title : Remo Indicator Mounting Drawing

Draw by : T.C.

Date : July 9, 2016

Scale : NIL

Drawing No. 16-7-1001

Assembly & Installation

The weighing scale is delivered in a partly dismantled condition. Assemble the individual components in the following sequence:

- Place your machine on a level, clean, and dry surface to obtain accurate readings.

Connecting the AC Adapter

The following Safety recommendations must be observed when connecting the balance:



The Scale should only be connected to the mains voltage socket with the power adapter supplied. Check before connecting the power adapter to the mains socket, that the operating voltage stated on the power adapter complies with the local mains voltage. If the operating voltage is not the same as the mains voltage, the power adapter must not be connected to the mains socket and contact customer service.

Placement of Scale

The location in which the scale is placed is very important in order for the scale to work to its full potential. Certain conditions can affect the capabilities of the scale, conditions like: the presence of air flow, variations in temperature, and direct sunlight. Please follow the recommendations given below in choosing a location to place your scale.

- Place the scale on a solid, firm and preferably vibration-proof, horizontal base
- Make sure that the weighing machine cannot be shaken or knocked over
- Protect from direct solar radiation
- Avoid drafts and excessive temperature fluctuations
- Avoid placing the scale near or on any magnetic surfaces.

FUNCTION SETTINGS

- Press and hold [HOLD] key then press [ON/OFF] key to turn on the scale, the display will show A-ON or A-OFF, press [ZERO] key to select (ON means auto power off function activate, OFF means auto power off function inactivate).
- Press [UNIT] key, the display will show L-ON, L-OFF or L-Au, press [ZERO] key to select (ON means auto backlight function activate, OFF means auto backlight function inactivate, Au means backlight under auto mode).
- Press [UNIT] key, the display will show P-XX. Press ZERO key to select OFF, key, con and Stb. (OFF means RS232 function inactivates, KEY means that you can output the data by pressing [PRINT] key. Con means that the data outputs continually. Stb means that the data will output when the reading is stable).
- Press [UNIT] key, the display will show J-ON or J-OFF, press ZERO key to select (ON means showing zero when turning on the power, OFF means showing weight placed when turning on the power.)
- Press [UNIT] key, the display will show F-Nor or F-PEA or F-Ani., press ZERO key to select (Nor means normal weighting function is activate. PEA means peak hold weighing function is activate. Ani means animal weighting function is activate).
- Press [UNIT] key, the display will show N-dsp or N-Ind. Press ZERO key to select (dsp means it can display synchronously as a display for another indicator through the RS232 output. Ind means it works only as an indicator for the scale)
- Press [UNIT] key, the display will show Kd 50 or Kd 100 or Kd 200 or Kd400, press [ZERO] key to select animal scale anti-shock range among 50, 100, 200, and 400.
- Press [UNIT] key, the display will show Fd 0.5 or Fd 3 or Fd 5 or Fd 10, press [ZERO] key to select animal scale filter range among 0.5, 3, 5,10.
- Press [UNIT] key, the display will show Ft 1 or Ft 2 or Ft 3 or Ft 4., press [ZERO] key to select animal scale filter time among 1,2,3,4.
- Press [UNIT] key, the display will show U-on or U-off, press [ZERO] to select U-on or U-off, U-on means you can switch unit between kg and lb., U-off means lb. unit will be disabled.

*****NOTE: Kd, Fd and Ft work only in F-Ani mode.**

Peak Hold mode

In **FUNCTION SETTING 5**, please choose F-PEA. PEA means peak hold weighing function activated, before weighing, please press HOLD key.

HOLD FUNCTION

- Place the item on the Scale platform.
- Wait for the stable weight to be displayed.
- Press the HOLD key. The “. “Hold indicator will turn on.
- Remove the item from the Scale platform. He item's weight reading will remain on the display. Now you can also select Unit (Pounds or Kilograms) by pressing [UNIT] key.(LB cannot be selected if LB is disabled in function setting)
- Quit HOLD function: Once an item is weighed and the hold function is enabled, you want to quit HOLD function, press the HOLD key again to cancel the “. “Hold indicator and return the Scale to weight mode.

CAUTIONS:

- When the recharging sign “” indicates, please charge the battery for 8 to 10 hours. When the charging is done, the Orange indicates light will turn into Green. Over-time charging will cause permanent damage.
- To use only the charger (adapter) supplied with the indicator.
- If after recharging and the battery does not last long, replace with new battery.

Calibration

- Press and hold [ZERO] key then press [ON/OFF] key, the display will show CAPU=, press [UNIT] key to select full capacity unit kg or lb.(unit LB cannot be selected if the LB is disabled in FUNCTION SETTING), press [HOLD] key to confirm the selection.
- Press [HOLD] key again to enter next menu, the display will show CAP, press [UNIT] key to set full capacity, press [UNIT] key to move the flash digit to right, press [ZERO] key to increase the flash digit, press [HOLD] key to confirm the selection.
- Press [HOLD] key again to enter next menu, the display will show CALU=, press [UNIT] key to select calibration unit kg or lb(unit LB cannot be selected if the LB is disabled in FUNCTION SETTING), press [HOLD] key to confirm the selection.
- Press [HOLD] key again to enter next menu, the display will show CAL, press [UNIT] key to set calibration weight, press [UNIT] key to move the flash digit to right, press [ZERO] key to increase the flash digit, press [HOLD] key to confirm the selection (the calibration weight should be more than 2/3 of full capacity).
- Press [HOLD] key again to enter next menu, the display will show DIV, press [UNIT] key to select division, press [HOLD] key to confirm the selection.
- Press [HOLD] key again to enter next menu, the display will show Adb, press [UNIT] key to select (19.20), press [HOLD] key to confirm the selection. Now start the calibration as

following steps:

- Press [PRINT] key, the display will show CAL, then AD value, press [UNIT] key when the stable indicator lights, the display will show flash calibration weight, place the shown weight on the platform, press [UNIT] key when the stable indicator lights, the display will show -----, and AD value. Turn off the scale, and calibration is finished.
- Turn on the scale, place tested weight to check whether it is correct, if not, please repeat above instructions.

Maintenance & Service

DANGER

For maintenance-work, the balance must be disconnected from the power supply (remove power adapter plug from socket). Also ensure that the balance cannot be connected to the power supply during the work by a third party.

Make sure that no liquid spills into the scale while performing maintenance work. If liquid is spilled on the scale, it must be inspected by a service technician.

Regularly perform maintenance to the weighing pan and the weighing pan holder by removing any dirt or dust from under the weighing pan and on the weighing scale housing. Use a soft brush or a soft, lint-free cloth, moistened with a mild soap solution.

CAUTION

Never use solvents, acids, alkalis, paint thinners, scouring powders or other aggressive or corrosive chemicals for cleaning; these substances can cause damage to the surfaces of the scale housing.

Transportation & Storage

Your weighing machine is a precision instrument, treat it carefully. Avoid shaking, severe impacts and vibration during the transportation. Make sure that there are no marked temperature fluctuations during the transportation and that the weighing machine does not become damp (condensation).

If you would like to take the weighing machine out of service for an extended period, disconnect it from the electricity supply, clean it thoroughly (refer to Maintenance & Service) and store it in a place which meets the following conditions:

- No violent shaking, no vibrations
- Minimum temperature fluctuations
- No direct solar radiation
- Minimum moisture

Warranty

The products are under warranty against factory defects for a period of two (2) years from the date of shipment.

For Customers within the lower 48 states of the continental United States. LW Measurements will pay for freight both ways for the first 30 days after purchase. After 30 days expire the customer is responsible for shipping the product back to us. After the product is received we will inspect it and as necessary we will repair or replace and will ship the product back to the customer at our expense.

Any new scales returned for warranty must be properly packaged in the original box. If they are not properly packed an in the original box, the customer pays for shipping cost. If we determine there is a factory defect, we will pay for the shipping back. If we determine that it is not a factory defect, the customer will pay shipping.

For Customers outside the lower 48 States, including Mexico, Canada, Puerto Rico, Hawaii, Alaska and all other countries, customers must pay for shipping.

Our warranty does not cover misuse or neglect including but not limited to battery or water damage, overloading, and chewed or cut wires. If the product is found to have been misused or damaged by the customer, LW measurements is not responsible for the cost of return.

For warranty claims please go online to lwmeasurements.com and fill out the warranty submission form or call your customer service representative.