



Professional Weighing Equipment

Race Car Scales

Wireless Car Scale Set



Operation Manual

Table of Contents

<u>Section</u>	<u>Page</u>
Declaration of Conformity	3
Customer Service	4
Introduction	4
Safety	5
IP65 Protection	6
Weight Scale	7
Functions	8
Features	9
Application & Installation	9-10
Getting Started	11
Delivery	11
Assembly & Installation	12
Application Menu	13
Program Options	14-16
Calibration	16-17
Maintenance & Service	17
Transportation & Storage	17
Warranty	18

Declaration of Conformity

Declaration of conformity for apparatus with CE mark

We hereby declare that the product to which this declaration refers conforms to the following standards.

Electronic scale: Weigh Bar series

Imperial version

Metric version

MRC2000

MRC 6500

Mark applied	EU Directive	Standards
	2004/108/EC	EN 61326-1: 2006

Signature:



Boon Lim, R & D Manager

Date: 14. 09. 2018

LW Measurements LLC, 620 Carlson Court, Rohnert Park CA, 94928

Customer Service

USA

LW Measurements LLC
620 Carlson Court
Rohnert Park, CA 94928
USA

Tel: (707) 542-2185

FAX: (707) 542-3285

<http://lwmeasurements.com>

Introduction

What you should know about these Operating Instructions:

Tree® Professional Weighing Equipment products are simple to operate.

Nevertheless, you should read through these operating instructions in their entirety, so that you can make optimum use of the full potential and the diverse possibilities of the weighing machine in your daily work.

These operating instructions contain guidance in the form of pictograms and keyboard diagrams, which should help you in finding the required information:

For the labeling of potential hazards, please refer to the Safety proportion of this operation manual.

Safety

Representations & Symbols

Important instructions, which involve safety, are highlighted with the appropriate mark:



Safety recommendations

When using the weighing equipment in surroundings with increased safety requirements, the corresponding regulations must be observed.

The weighing scale may only be used with the power adapter supplied.

Before connecting the power adapter to the scale, the user must ensure that the operating voltage stated on the power adapter is compliant with the mains voltage. If not, please contact Customer Service at the address above.

If the power adapter or its cable is damaged, the weighing scale must immediately be disconnected from the electricity supply (pull out the power adapter).

If there should be any reason to believe that it is no longer safe to operate the scale, it should be immediately unplugged from the electricity supply (pull out power adapter) and secured against inadvertent operation.

In carrying out maintenance work, it is essential to follow the recommendations set out in maintenance and servicing.

The weighing scale must not be operated in an area subject to explosion risks.

Care must be taken when weighing liquids to ensure that no liquid is spilled into the inside of the scale or into connections on the rear of the equipment or the power adapter. If liquid is spilled on the scale, it must immediately be unplugged from the main electricity supply (pull out power adapter).

The weighing scale may be operated after it has first been inspected by a service technician.

These operating instructions must be read by each user and should be easily accessible at the workplace at all times.

Weight Scale

Construction & Functions

The weighing scale consists of the following parts;

- Digital indicator (1)
- Scale pads (4)
- The adapter (1)
- Operation manual

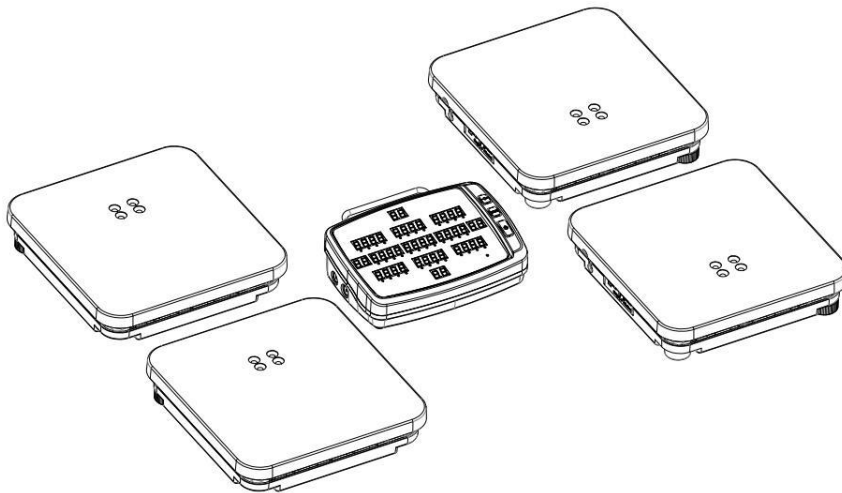
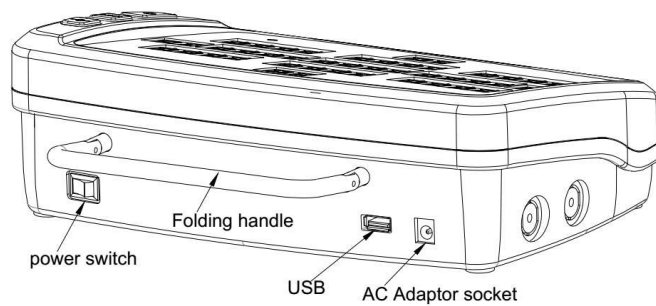

Functions

The Race Car Scales are high-quality electronic precision weighing devices with the following specifications

Specifications

Model number	Capacity	Division	Weighing Platform Size
MRC 2000	4 X 550 lb.	0.2 lb.	12 x 12.6 inches / 31 x 32 cm
MRC 6500	4X1650 lb.	1 lb.	35 cm x 40 cm/ 14 inch x 16 inch
Net/gross weight	22 kg / 25 kg (44lg / 55lb) 31.5 kg/35.8 kg (69.3 lb/89.5 lb)		
Package (Standard carton)	67x39.5x40(cm ³) 26.4x15.6x15.7 (inch ³) 64.50x50.5x43 (cm ³) 25.4x19.9x16.9 (inch ³)		
Operating Temp.	0-40°C (32-104°F)		
Power source	6 V/4AH (not included) or AC/DC Adapter 12V DC / 1000mA		

FEATURES

- Display options: 44 digital LED
- Power: recharge/AC adapter 12V/1000mA
- Select LED brightness (selectable)
- Auto shut off (selectable)
- Operating Temperature: 5-35 °C
- Operating Humidity: 25%-95% RH
- Zero Range (4% to full capacity)
- Tare Range (50% to full capacity)
- Low battery will appear - charge
- Error message indication:
 - [Err-O] = Overload
 - [Err-Z] = Exceed zero track range when power is on
 - [Err-S] = Unstable when power is on
 - [Err-C] = calibration code is not enough or operation error

Application & Conformity

The Following are instructions of how to correctly use the weight scale:

The weighing scale may only be used for the weighing of solid-materials and of liquids filled into secure containers.

The maximum capacity load of the weighing scale must never be exceeded, otherwise the weighing scale may be damaged.

In using the weighing scale in combination with other devices as well as with devices produced by other manufacturers, the appropriate regulations for the safe use of the relevant attachments and their application in accordance with instructions must be observed.

The weighing scale has been manufactured and tested in accordance with the standards and recommendations set out in the declaration of conformity.

The power adapter supplied for the weighing scale complies with the appropriate electrical protection class.

The following applies to Weigh Bar series

Power supply:

Input: 110 or 230V AC (+/-15-20%); 50 to 60Hz

Output: 12V DC 150mA

Allowable ambient conditions

Temperature: 5°C - 40°C

Relative humidity: 25% - 85%, non-condensing

If you have any questions on the technical data or require detailed technical information on your balance, please contact your technical representative.

The scale is packaged in an environmentally-friendly carton, which provides optimum protection for the balance during transportation.

We suggest that you keep the original packaging in order to avoid damage if you are shipping or transporting the scale to a different location. It is also the best way to keep it in the best conditions if it will not be used for an extended period of time.

In order to avoid damage, please follow the instructions provided below, when unpacking the scale:

- Unpack the scale carefully.
- When outside temperatures are very low, the scale should be stored for a couple hours and kept in its box in a dry room at normal temperature, so that no condensation settles on the unit when opening the box.
- Check the scale immediately after unpacking for any external visual damage. If there is any damage on scale, contact customer service immediately.
- If the scale is not to be used immediately after purchase, it should be stored in a dry place where fluctuations in temperature are low. (Reference pg.6).
- Read through these operating instruction, before you work with the unit and pay attention to the Safety recommendations (reference Safety pg. 5).

Delivery

Inspect delivery for completeness immediately on unpacking all components.

Checklist for complete delivery

	Component delivered present: yes / no
Digital Display	
Scale pads (4)	
Power adapter	
Operating manual	

Assembly & Installation

The weighing machine is delivered in partly dismantled condition. Assemble the individual components in the following sequence:

- Insert the power adapter cable plug into the socket at the rear of the balance.

Connecting the AC Adapter

The following Safety recommendations must be observed when connecting the balance:



Placement of Scale

The location in which the scale is placed is very important in order for the scale to work to its full potential. Certain conditions can affect the capabilities of the scale, conditions like: the presence of air flow, variations in temperature, and direct sunlight. Please follow the recommendations given below in choosing a location to place your scale.

- Place the scale on a solid, firm and preferably vibration-proof, horizontal base
- Make sure that the weighing machine cannot be shaken or knocked over
- Protect from direct solar radiation
- Avoid drafts and excessive temperature fluctuations
- Avoid placing the scale near or on any magnetic surfaces

Application Menu

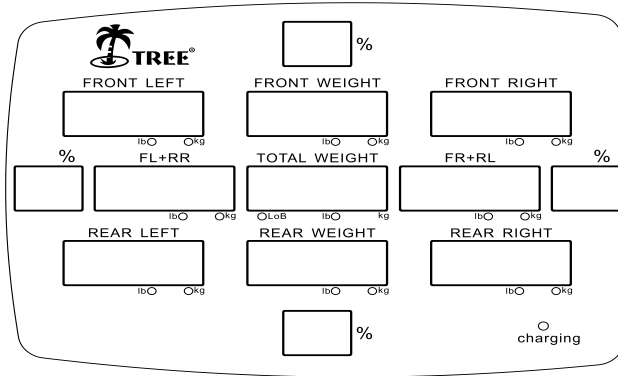

Display overview

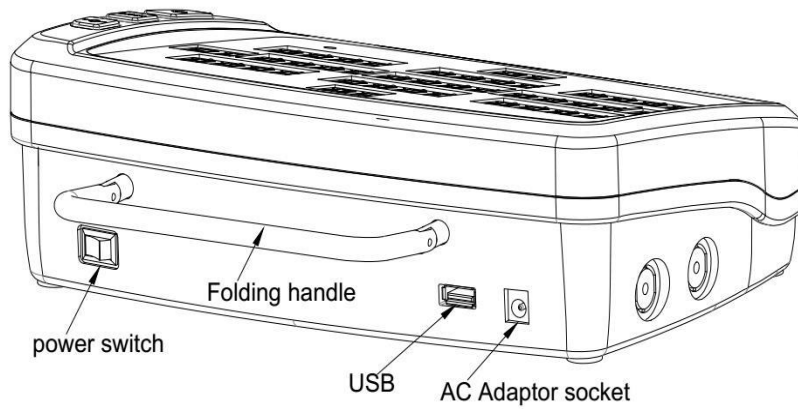

Key Functions:

- The ON/OFF key is to turn the Scale On or Off
- The UNIT Select weighing units: kg or lb
- The ZERO key: Zero for Tare
- The PRINT key is to send data to external device through RS232 connector.

Interface

Interface Settings

- Battery socket: AC/DC 12V – external positive, inner negative
- USB interface:

Press and hold [ZERO] key then turn on the scale, the display will show A-ON or A-OFF, press [UNIT] key twice, the display will show P-Con or P-PC, press [ZERO] key to select Con or PC.

P-Con: send data continuously

P-PC: order send: host sends 0A (HEX) order, scale will send below data

Port setting: 9600, N 8, 1

Port's data format: (48 Bytes)

Byte 1~3 4~8 9~10 11 12

MODE DATA UNIT CR LF

1~3. MODE='FL:' : front left weight

MODE='RL:' : front right weight

MODE='FR:' : rear left weight

MODE='RR:' : rear right weight

4~8. DATA : weight data

9~10. UNIT='kg'/'lb' : unit

11. CR : ENTER key(HEX=0D)

12. LF : change line(HEX=0A)

Features :

1. Display options : 44 digital LED
2. Power: recharge / AC adapter 12V/1000 mA
3. Select LED brightness (selectable)
4. Auto shut off (selectable)
5. Operating Temperature : 5~35°C
6. Operating Humidity : 25%~95%RH
7. Zero Range (4% to full capacity)
8. Tare Range (50% to full capacity)
9. Error Message indication :
 - Err-O Overload
 - Err-Z Exceed zero track range when power is on
 - Err-S Unstable when power is on
 - Err-C Calibration code is not enough or operation error. -Lo- Scale Low battery indication
 - Link it means that the Bluetooth connection failed.
 - Lo- indicator Low battery indication
10. Two calibration weight units: kg, lb.
11. Open calibration capacity
12. Power on zero-setting range: + 10%
13. Bluetooth indicator.
14. Three modes: J-ON mode: showing zero when turn on the power / J-OFF mode: showing weight placed when turn on the power. /Internal Auto Calibration mode
15. USB function

Battery

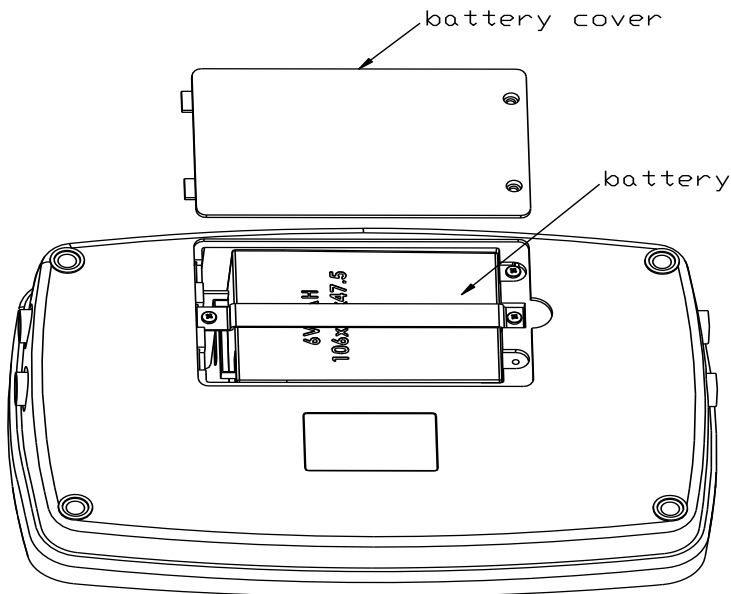

CAUTIONS:

1. When the recharging sign “LoB” indicates, please charge the battery immediately. When the charging is done, the indicate lights will turn orange color into green color. Remove the adaptor when charging finished, and over-time charging will cause permanent damage.
2. If the display FRONT LEFT (or rL/Fr/rr) shows “-LO-” “weight” alternately, it means the battery of the FRONT LEFT scale (or rL/Fr/rr) is in low voltage, please charge the battery immediately. When the charging is done, the indicate lights will turn orange color into green color. Remove the adaptor when charging finished, and over-time charging will cause permanent damage.
3. You must use the charger (adapter) supplied with the indicator.
4. If after recharging and the battery does not last long, replace with new battery.

Work mode:

Connect the 4 scales to its corresponding indicator. (indicator’s FRONT LEFT socket connect to RONT LEFT scale, indicator’s REAR LEFT socket connect to REAR LEFT scale) . Set the switch on the edge of the weighing pan to ON.

1. Press **[ON/OFF]** key, the scale starts self-inspection and show 9-8-7.....1----. At the same time, the indicator and the Bluetooth indicate light on the scale flashing, it means the indicator and the scale

are online, if online succeed, the Bluetooth indicate light will become light constantly. 4 scales in zero mode. (NOTE : when the scale with nothing while the indicator shows weight, please check whether the connection between indicator and scale is caused by low voltage. Please connect the adapter to charge the indicator and the scale.

Pick up the race car, put FRONT LEFT, REAR LEFT, FRONT RIGHT, REAR RIGHT scale under its corresponding wheel, place the race car smoothly the display will show each wheel's weight, front, rear, left, right weight and

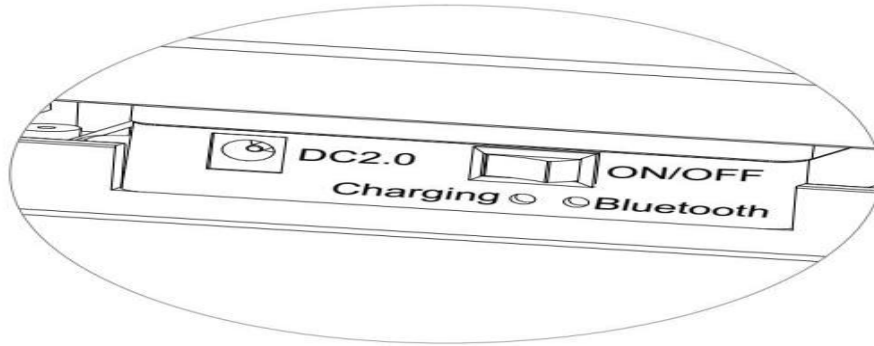

percentage.

NOTE :

1. If the indicator displays "Link", it means that the Bluetooth connection failed. Please check whether the corresponding scale's Bluetooth indicate light is flashing or light constantly. If the indicate light is on, please restart the scale.
2. If the indicator displays "Link" and the corresponding scale's Bluetooth indicate light don't work, restart the scale and the Bluetooth indicates still off, please connect the special adapter to charge the battery. When the charging is done, the indicate light will turn Orange color into Green color.

When to calibrate

Calibration may be required when it is initially installed, if the scale/balance is moved to a substantial distance.

This is necessary because the weight of a mass in one location is not necessarily the same in another location. Also, with time and use, mechanical deviations may occur.

Calibration Weight

Connect the 4 scales to its corresponding indicator. Indicator's FRONT LEFT socket connect to FRONT LEFT scale, indicator's REAR LEFT socket connect to REAR LEFT scale) .

1. Turn on hard switch on bottom front right of indicator press and hold [UNIT] key then press [ON/OFF] key, the display will show CALI, FL press [UNIT] key to select calibrate scale .FL/rL/Fr/rr;
2. Press [ZERO] key the display will show CALu, press [UNIT] key to select calibration unit kg or lb;
3. Press [ZERO] key, the display will show CAL= Xxx.x,(press [UNIT] and [ZERO] key to enter setting calibration weight) ,press [UNIT] key to move the flash digit to right, press [ZERO] key to increase the flash digit, press [ON/OFF] key to confirm the selection (the calibration weight should be more than 1/2 of full capacity). CAL0 0,Press [UNIT] key, the display will show CAL0, then AD value, press [UNIT] key, the display will show flash calibration weight, place the shown weight on the FL platform, press [UNIT] key, the display will show ----, the display will show flash FL (or rL/Fr/rr).you can remove the weights. FL (FRONT LEFT scale) calibration finished. Press [UNIT] key to select calibrate scale rL /Fr/rr. Now calibration is finished and you can remove the weights. Turn off the scale.

Turn on the scale, place tested weight to check whether it is correct, if not, please repeat above segments.

Maintenance & Service

The weighing machine must be treated carefully and cleaned regularly. It is a precision instrument.



For maintenance-work, the balance must be separated from the power supply (remove power adapter plug from socket). Also ensure that the balance cannot be reconnected to the power supply during the work by a third party.

See Section 1.3 above regarding IP65. The scale may be washed down.

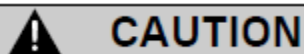

Never use solvents, acids, alkalis, paint thinners, scouring powders or other aggressive or corrosive chemicals for cleaning; these substances can cause damage to the surfaces of the scale housing.

Transportation & Storage

Your weighing machine is a precision instrument, treat it carefully. Avoid shaking, severe impacts and vibration during the transportation. Make sure that there are no

marked temperature fluctuations during the transportation and that the weighing machine does not become damp (condensation).

If you would like to take the weighing machine out of service for an extended period, disconnect it from the electricity supply, clean it thoroughly (refer to Maintenance & Service) and store it in a place which meets the following conditions:

- No violent shaking, no vibrations
- Minimum temperature fluctuations
- No direct solar radiation
- Minimum moisture

Warranty

The products are under warranty against factory defects for a period of two (2) years from the date of shipment.

For Customers within the lower 48 states of the continental United States. LW Measurements will pay for freight both ways for the first 30 days after purchase. After 30 days expire the customer is responsible for shipping the product back to us. After the product is received we will inspect it and as necessary we will repair or replace and will ship the product back to the customer at our expense.

Any new scales returned for warranty must be properly packaged in the original box. If they are not properly packed in the original box, the customer pays for shipping cost. If we determine there is a factory defect, we will pay for the shipping back. If we determine that it is not a factory defect, the customer will pay shipping.

For Customers outside the lower 48 States, including Mexico, Canada, Puerto Rico, Hawaii, Alaska and all other countries, customers must pay for shipping.

Our warranty does not cover misuse or neglect including but not limited to battery or water damage, overloading, and chewed or cut wires. If the product is found to have been misused or damaged by the customer, LW measurements is not responsible for the cost of return.

For warranty claims please go online to lwmeasurements.com and fill out the warranty submission form or call your customer service representative.