

# C A M B R I D G E

## MODEL SSCSW-10AT-CS SERIES STAINLESS STEEL CRANE SCALE



### Applications:

- Food Processing
- Fish Hatchery
- Seafood Markets
- Outdoor / Harsh Environment
- Tournament Weighing

### Standard Features Include:

- Food Grade Stainless Steel Enclosure
- IP 67 Rated Environmental Sealed Enclosure
- Battery Operation - 32 hrs. between charges  
Includes Battery and External Wall Battery Charger
- Selectable Sleep Mode to Conserve Battery Power
- Weight Totalization
- Net / Gross Display Modes
- Full Range Auto Tare
- Adjustable Sample Rate
- Digital Filtering
- All Pushbutton Controls
- .56" LED Display with Selectable Brightness
- On / Off Switch
- Center of Zero Annunciator
- Lb / Kg Conversion
- Span Adjustment at Increasing or Decreasing Weights
- 1 to 5 Points of Digital Calibration
- Full Range Push Button Zero
- Auto Zero Tracking
- Adjustable Motion Detection
- 150% Safe Overload of Load Cell
- 300% Ultimate Overload of Load Cell
- Keypad Calibration with Audit Trail
- Light Weight for Easy Handling and Transport.  
15 - 25 lbs depending on capacity. See back page for optional ultra-tough carrying case.
- Stainless Steel Shackles
- Nickel Plated Hook

### Approvals:



### Members:

- THE NATIONAL CONFERENCE ON WEIGHTS AND MEASURES
- THE INTERNATIONAL SOCIETY OF WEIGHING AND MEASUREMENT

# CAMBRIDGE

## MODEL SSCSW-10AT-CS SERIES STAINLESS STEEL CRANE SCALE

Model Number	Capacity & Graduation	S.S. Shackle & Nickel Plated Hook	Approx. Ship Weight
SSCSW-10AT-CS-500	500 lbs. X .1 lbs.	2 Ton Shackle / 1.5 Ton Hook	15 lbs.
SSCSW-10AT-CS-1K	1,000 lbs. X .2 lbs.	2 Ton Shackle / 1.5 Ton Hook	15 lbs.
SSCSW-10AT-CS-2K	2,000 lbs. X .5 lbs.	2 Ton Shackle / 1.5 Ton Hook	15 lbs.
SSCSW-10AT-CS-5K	5,000 lbs. X 1 lb.	5 Ton Shackle / 5 Ton Hook	23 lbs.
SSCSW-10AT-CS-10K	10,000 lbs. X 2 lbs.	5 Ton Shackle / 5 Ton Hook	25 lbs.



Includes batteries (2) and external wall mount charger.



### Options:

- Crane Overload Warning System

### Accessories:

- Rugged Storage Carrying Case
- Spare Battery

*Optional Rugged Storage-Carrying Case shown with optional Spare Battery*

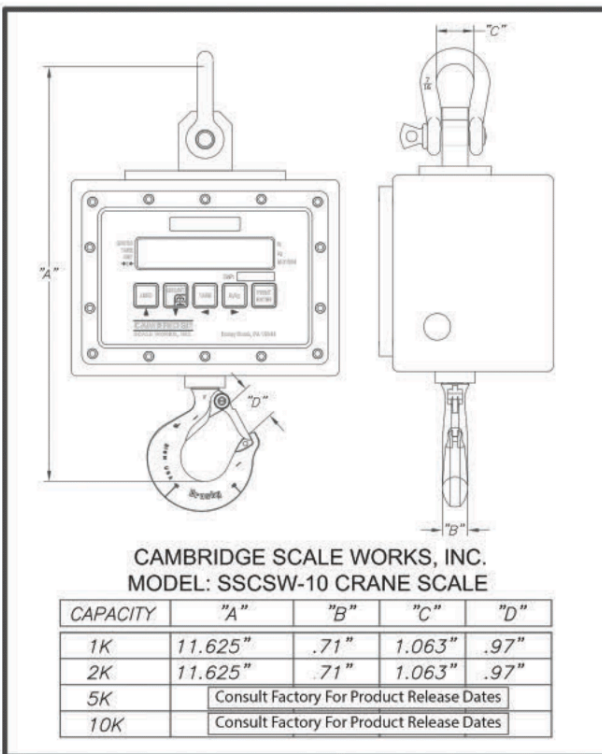

*The Cambridge Model SSCSW-10AT-CS makes the perfect rugged, weather proof and accurate scale for fishing tournament weigh ins.*

*The stainless steel enclosure is virtually impervious to salt water.*

*The light weight design and battery operation create a portable, easy to set up scale that can handle the biggest fish your competitors bring to the dock.*